

# HI-LIGHTER

THE QUALITY DIAGNOSTIC INSPECTION LIGHT FOR INDUSTRIAL OBJECTS & PROCESSES IN MOTION



QUALITY THROUGH LIGHTING



WITH  
BUILT IN  
DIGITAL  
CONTROL



WITH  
SEPARATE  
DIGITAL  
CONTROL  
AND  
YOKE



## FEATURES

- Industrial Quality
- Self-Contained
- Light Weight
- High Light Output
- Long-Life Lamp
- "Step Lock" Precision Phase Control
- Adjustable Intensity
- Short Flash Duration
- Remote Control
- Safety Indicating Circuit
- Removable Yoke
- Syncs to Camcorders
- Removable Side Handles

## SPECIFICATIONS

w/Yoke 419 x 330 x 177mm; 7.3kg  
(16.5 x 13 x 7in; 16lbs)

w/o Yoke 330 x 330 x 177mm; 6.4kg  
(13 x 13 x 7in; 14lbs)

Shipping Case 480 x 460 x 280mm, 7.3kg  
(19 x 18 x 11 in; 15lbs)

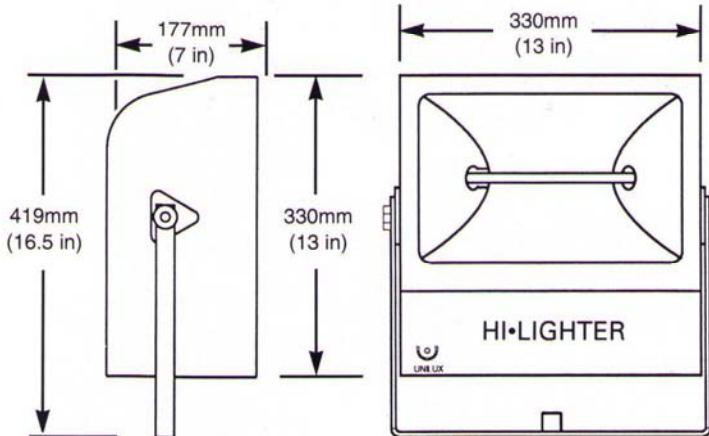

MODEL	FLASH RATE		MAXIMUM FLASH ENERGY (J)*	LIGHT OUTPUT†	
	RPM	Hz		LUX	FC
HI-4.8	4800	80	5.6	11,000	1,000
HI-6.0	6000	100	4.7	9,000	830
HI-12	12000	200	2.4	3,600	330
HI-24	24000	400	1.2	1,400	130

\*When Intensity is set for 100%;

†At 760mm (30in) when intensity is set for 100%

## CONTROLS

- Master Power Switch  
Includes Safe Operating Indicator
- Brightness: 35%, 50%, 75%, 100%
- Phase UP - Phase Down
- Mode - 4 Settings
  - Flashes per Second
  - RPM (Flashes per Minute)
  - External Trigger
  - External Trigger w/Phase Delay

## FLASH DURATION & POWER

- 20 Micro Seconds
- Power Input;  
Any AC Input from  
90-250V; 50/60 Hz  
650VA Max



# HI-LIGHTER